

SERIE 800 II pieghevole scorrevole

SERIES 800 The folding sliding door



Sistemi pieghevoli per mobili / Folding systems for furniture

KIT 0813/2 - MAX 40 KG

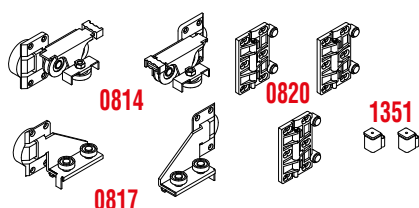

Legenda KIT / Kit Legend

0814	Carrello superiore laterale DX-SX <i>Left hand-right hand side upper truck</i>
0817	Guida inferiore laterale DX-SX <i>Left hand-right hand side lower runner</i>
0820	Cerniera Derlin a scatto <i>Derlin snap hinge</i>
1351	Fermo inferiore nylon <i>Lower nylon stopper</i>

Legenda altri componenti Legend other items

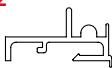
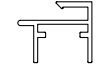
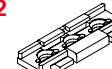
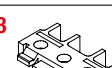
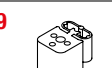
0812		Profilo alluminio superiore <i>Upper aluminium profile</i>
0272		Profilo alluminio inferiore <i>Lower aluminium profile</i>
1342		Supporto a scatto basso per ART.0812 <i>Upper low clip for ART.0812</i>
1353		Supporto a scatto alto per ART.0272 <i>Lower high clip for ART.0272</i>
0819		Fermo superiore nylon <i>Upper nylon stopper</i>

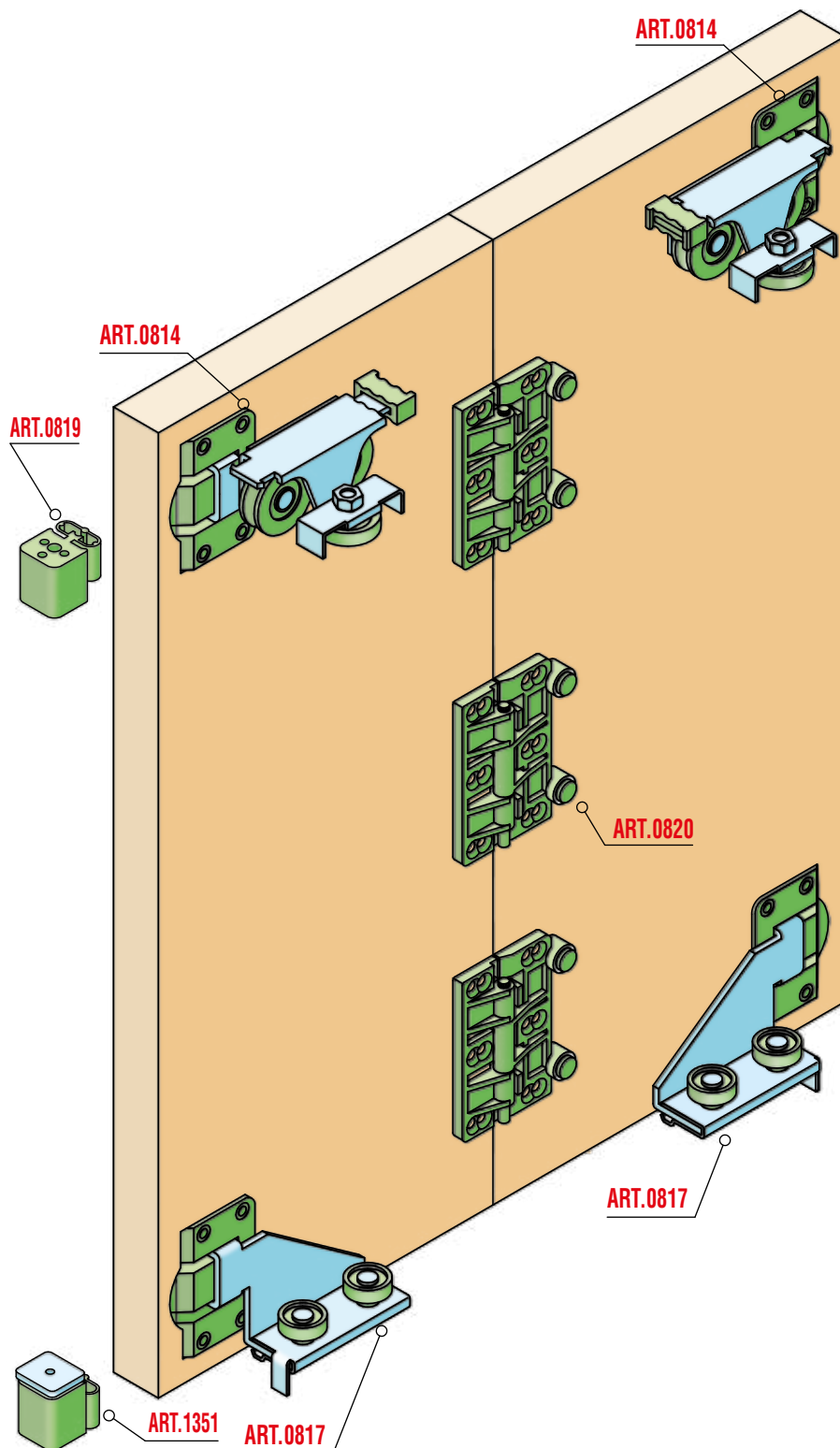



Sistemi scorrevoli per armadi / Folding systems for furniture

Schema foratura ante / Doors drilling

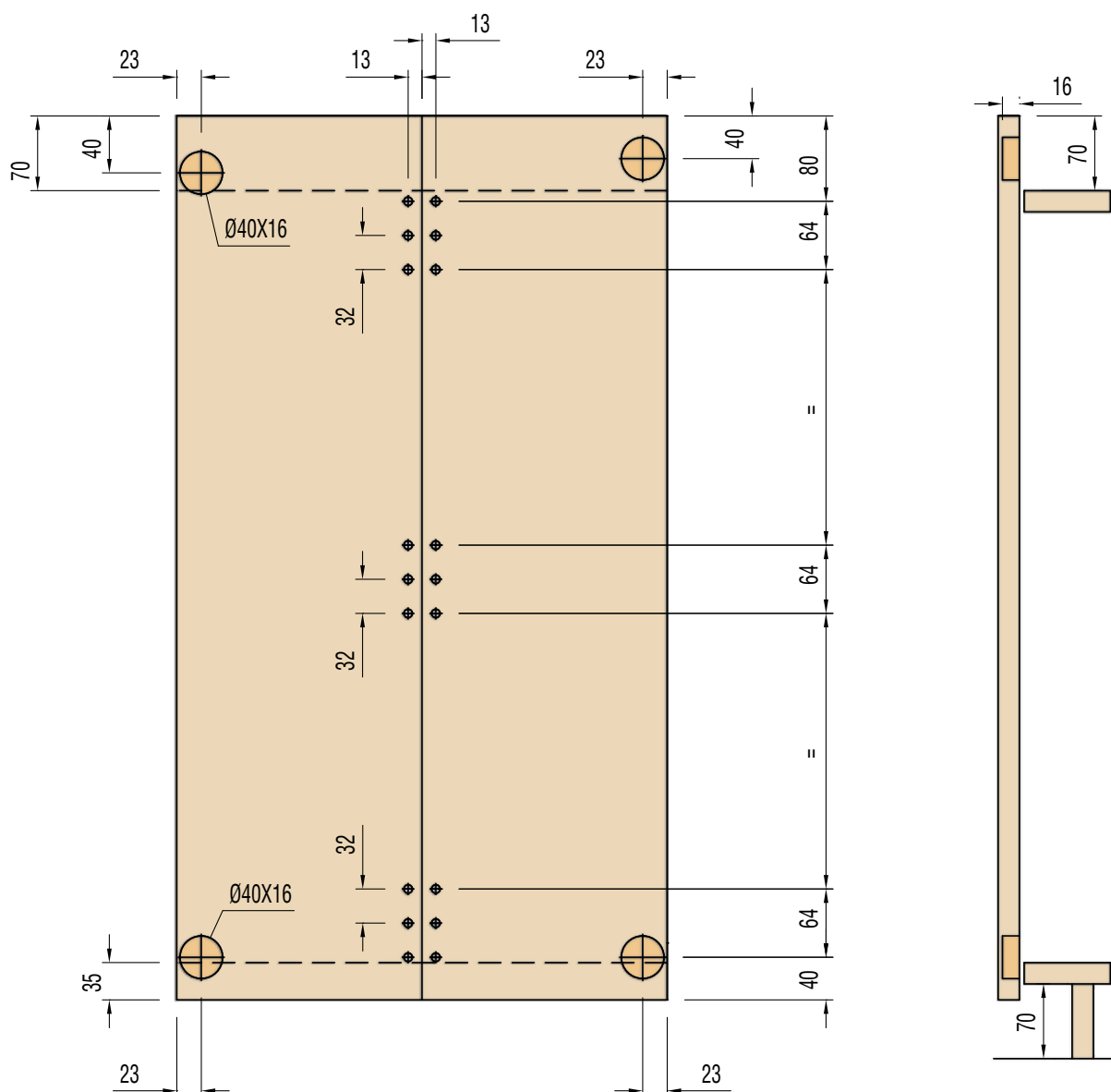

Dimensione minima di ingombro / Minimum overall dimension

SISTEMA A DUE ANTE / SYSTEM FOR TWO DOORS

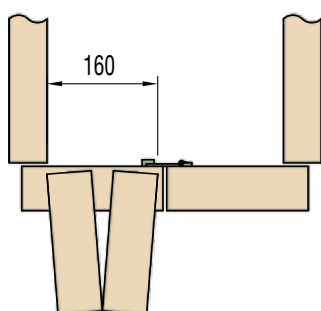

Schema di montaggio / Assembling

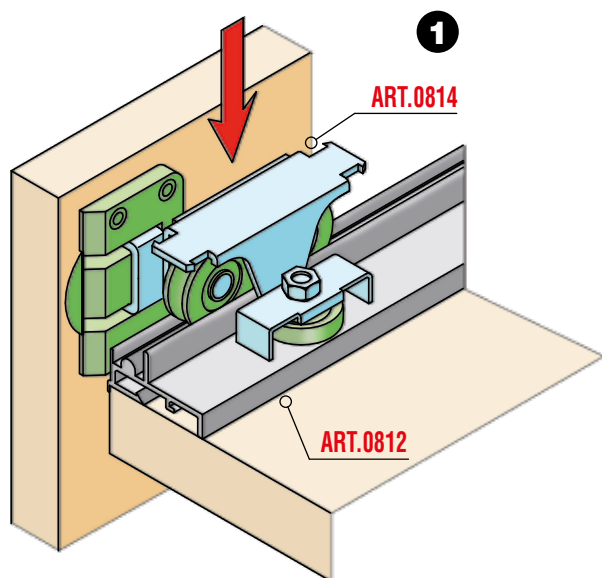

ISTRUZIONE DI MONTAGGIO

- 1 Posizionare le ante sul relativo binario superiore.
- 2 Unire le ante fra loro, assemblando le ali premontate delle cerniere, ART.0820, tramite l'apposito perno.
- 3 Inserire le slitte di scorrimento sulle staffe inferiori ART.0817-0818.
- 4 Posizionare il fermo superiore tramite la vite autofilettante "C" ed il fermo inferiore mediante la piastrina filettata.

ASSEMBLING INSTRUCTIONS

- 1 Place the doors on the upper truck.
- 2 Join the doors together by securing the preassembled flanges of the hinges ART.0820 by means of pin.
- 3 Fasten the slides to the brackets of the lower trucks ART.0817-0818.
- 4 Place the upper stopper through the self-threading screw "C" and the lower stopper trough the threaded plate.

